

Berlingtone

Vocal Performance Dynamic Microphone



BR-400UM

Berlingtone

USER MANUAL

BR-400UM

UHF Wireless Microphone System

4 Channels Professional Wireless UHF Cordless Microphone

TECHNICAL FEATERS

RECEIVER SPECIFICATIONS:

1. Frequency Range: 475-580MHz
2. Frequency Response: 50Hz--16KHz
3. Sensitivity: -90dBm
4. T.H.D.: ≤0.5%
5. D/N: 37 μV
6. Mix Output: 300mV
7. Balance: 150mV
8. Power Supply: 12-15V

TRANSMITTER SPECIFICATIONS:

1. Frequency Range: 475-580MHz
2. Frequency Response: 50Hz--16KHz
3. Sensitivity: -90dBm
4. S/N Ratio: 91dB
5. Frequency Bandwidth: 300KHz
6. Transmitter Power: 8dBm
7. Transmission Speed: 204.8Kbps

ATTENTION:

- 1) Please make sure to use the correct power supply: DC 12-15V.
- 2) If the item is not used for a long time, please move the power supply out from the power outlet.
- 3) Please pull out the Ant. when using this system.
- 4) To avoid electronic shock risk, do not open the receiver and transmitter box by your own, and can not change any accessories in the box.
- 5) Keep the whole system away from the liquid, dusty or some hot place, just like water, oil, fire, ect..
- 6) Do not knock or hit or beat the whole system to avoid damage.
- 7) Keep the microphones 5-10cm away from mouth in order to obtain good results.
- 8) Use or change the new professional Alkaline batteries when the power of batteries is not enough.
- 9) Do not use the microphones with same frequency to avoid interference.
- 10) Please use soft fabric to clean the whole system to avoid damage.

4

PACKING LIST

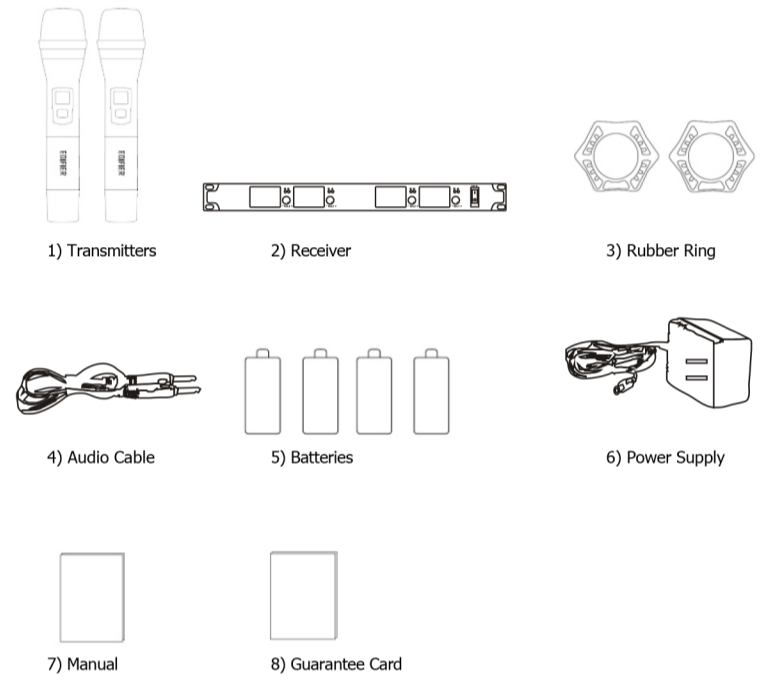

RECEIVER FRONT PANEL

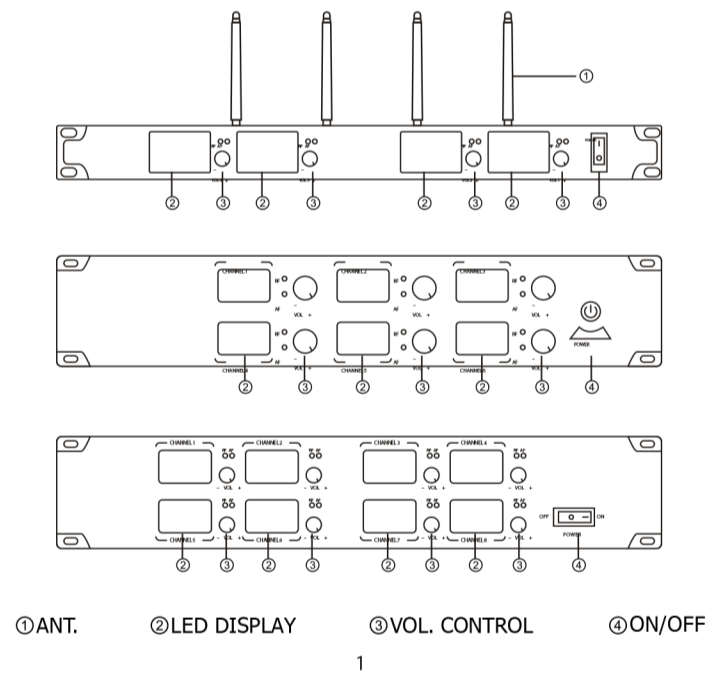

1

RECEIVER BACK PANEL

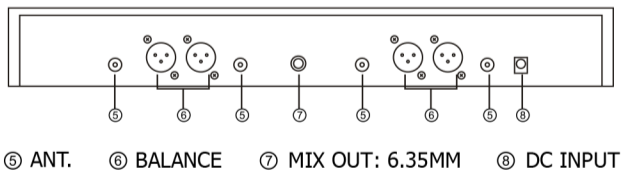

TRANSMITTERS

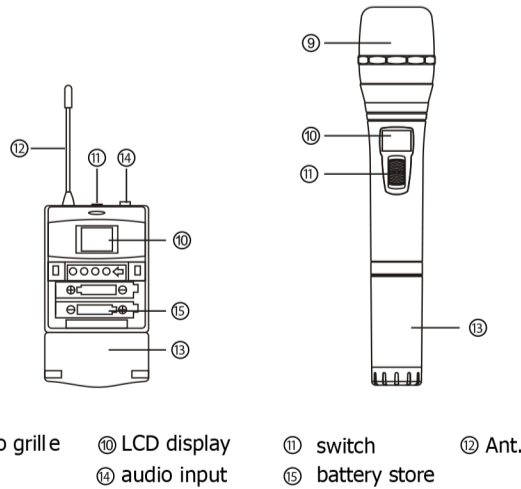

INSTALLATION

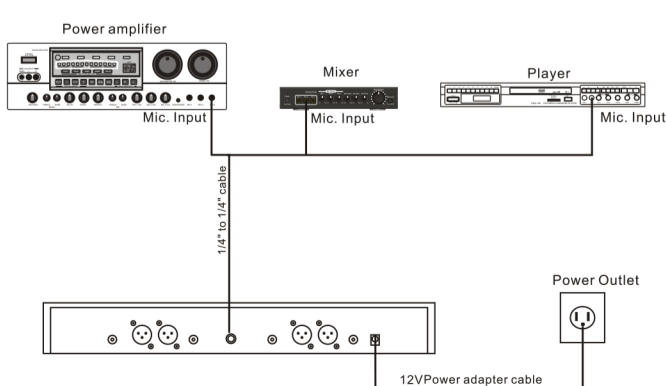

- 1) The power supply is connected to the power jack of the receiver.
- 2) Connect one audio cable with end of 1/4" to 1/4" plug to the receiver's MIX OUT, and another end to a karaoke mixer or power amplifier or any other karaoke player microphone input. If you are using the BALANCE AUDIO OUTPUT, use a XLR to XLR cable or XLR to 1/4" cable.

2

- 3) turn off the volume of the receiver

- 4) open the transmitters battery cover to check if there has batteries or not inside. If there is no batteries, pls put the batteries into the battery store of the transmitter, and then close this battery cover again.

- 5) tun on the receiver and transmitters, and then increase the volume step by step.

TROUBLESHOOTING

If you are having operating problems, or suspect something wrong with the unit, please check the troubleshooting list below to see if the issue is a result of incorrect operation rather than equipment malfunction.

Problem	Possible cause	Solution
Receiver No sound; No lights	<ul style="list-style-type: none"> • Power button is on the OFF position • DC power adater is not plug in • Poor connection of DC power adapter • How to switch from different channels? 	<ul style="list-style-type: none"> • Turn on the power button • Plug in the DC power adapter • Check to see if the DC power adapter is loose. • See page 3 for details.
Microphone No sound; Lights on	<ul style="list-style-type: none"> • The transmitter is out of range • Microphone switch is off or mute • Microphone volume is turned down • Batteries in the microphone are not installed properly • The antenna is not fully functional. • Receiver is not connected to an amplifier, mixer or karaoke player 	<ul style="list-style-type: none"> • Operate the machine in the effective range • Turn on the microphone switch (indicated green light) • Turn on the microphone volume of the receiver • Reinstall the batteries. Make sure the positive and negative end are install correctly • Try to change the angel of the antenna • Connect the 1/4 to 1/4 cable from the receiver to a microphone input (mixer, player, etc.). See Page 4 for detail
Distorted sound; feedback	<ul style="list-style-type: none"> • The two microphones are too close together • Batteries running low in microphone • Microphone volume is too high • Distortion from other electric wave 	<ul style="list-style-type: none"> • Separate the microphone further away • Replace the batteries • Reduce the volume of the microphone • Move the receiver away from electric equipment
Batteries	<ul style="list-style-type: none"> • Batteries are bad or off power 	<ul style="list-style-type: none"> • Replace the batteries.

3