

Berlingtone

PROFESSIONAL

MIXER

BR-118MX - BR-124MX



Owner's Manual

PRECAUTIONS

Safety Instructions-

*Lt.*WARNING

- Do not allow water to enter the device, or make it wet. Doing this may result in fires or electric shocks.
- Do not place containers filled with liquid or small metal objects on this device. Or the liquid or small metal objects may fall into the device and result in fires or electric shocks.
- Do not place heavy objects (including this device) on the power cord. Otherwise it may damage the cord, thus resulting in fires or electric shocks. Take special notice not to place heavy objects on the cord covered under the carpet.

- Do not cut, bend, twist, stretch or heat the power cord. Otherwise, it may damage the cord, thus causing fires or electric shocks.
- Do not open the cover shell of this device. Or, it may result in electric shocks. If you consider it necessary to detect, maintain or repair the internal parts, please contact the sales agent.

- When there are electrical storms, turn off the power switch of this device and remove the power plug.
- When there is lightening, do not touch the power plug in the condition of being connected. Otherwise, it may result in electric shocks.
- This device can only be used with the AC power adaptor (PA-30) supplied with the appliance. Using adaptors of other models may result in fires or electric shocks.

- If the AC adaptor falls down from high or has its shell damaged, please turn off the power switch immediately, disconnect the power plug from the AC power outlet, and contact the sales agent. Continuing to use in ignorance of this notice may result in fires or electric shocks.
- If you find any abnormality such as smoking, smelling, noise, foreign matters or liquid entering the interior of this device, immediately turn off the power switch, disconnect the electric plug from the outlet, and have the device repaired by the sales agent. Continuing to use may result in fires or electric shocks.

Lt. CAUTION

- Avoid using this device in the following occasions:
 - Exposure to the splashing oil or steam in the places such as close to kitchen ovens, moisturizers, etc.
 - On unstable surfaces, such as shaking table surface or slanting surface.
 - Exposure to overheating places such as in a car with windows shut or under the direct sunlight.
 - Exposure to the places with high moisture or piling-up dirt.
- When removing the electric plug from an AC power outlet, do not pull the cord by itself. Pulling by the cord can damage it, and result in fires or electric shocks.

- Do not touch the power plug with wet hands. Or it may result in electric shocks.
- If you want to move this device, disconnect the power plug from the AC power outlet first, and remove all connecting cables. It may otherwise damage the cables and cause fires or electric shocks.

- Do not use cloth or carpet to cover or wrap the AC power adaptor. Otherwise the heat will accumulate in the cloth or carpet, melting the shell of the adaptor or causing fires. Use it under good ventilation.

correct operation instructions

- The XLR connector shall be wired as shown below
Needle 1: ground wire; Needle 2: hotline(+); Needle 3: cold thread(-).
- INSERT IRS headphone jack wiring is as follows
Sleeve: ground wire; Tip: signal transmission; Loop: return signal.

- The constant dynamic contact, such as switches, rotary controls, attenuators, and connectors, declines over time. Although the wear rate varies greatly with the use conditions, a certain degree of wear is unavoidable. In case of parts failure, please contact the dealer for replacement.

Use your mobile phone away from the device when making noise.

- Turn off the power when the mixer is not in use.
- Even if the power switch is placed in the (standby) position, there is still a small amount of current in the mixer. Be sure to remove the power plug from the AC socket when it is determined not to be used for a long time.

The illustrations in this manual are for illustration only and may differ from the appearance in actual use. Interference from cellular phone calls. Material to replace the division of labor of each needle connected to the socket is correct operation instructions. The instructions

Preface

This mixer is easy to operate and can support various environments. It is an ideal equipment for setting up, installing systems and many other purposes.

In order to maximize the super function of this mixer and extend its normal service life, please read this user manual carefully before use.

- Multiple input channels can be provided and these signals can be mixed into stereo sound and grouped output signals.
- Because of the high quality of the inherent digital effect, itself can directly provide a wide range of effects. It also comes with a SEND socket that can be connected to external effectors.
- PHONES jacks are available on the monitor. The socket can be used to monitor the main stereo output signal, PFL signal or 1-2 groups of signals.
- The mixer is also equipped with AUX SEND jack and a single RETURN jack. AUX communication buses transmit signals to external effectors and monitoring systems.
- The virtual power supply can provide convenient connection for capacitor microphones that need external power supply.
- Mono input channels are respectively equipped with XLR microphone input jack and TRS earphone linear jack. Stereo input channels are equipped with TRS linear input ports and RCA linear input ports. These various socket integrations enable the mixer to be connected to many different types of sound source devices such as microphones, linear level devices and even stereo output synthesizers.

Note.....	1
Introduction /directory	2
Basic operation.....	3
Quick guide.....	4
The front panel and rear panel..... (channel control part)	5
The front panel and rear paneJ:..... (channel control part)	6
The front panel and rear pane)..... (main control part)	7
The front panel and rear pane)..... (main control part)	8
Digital effects list	9
Theinput specifications	10
List of digital effects.....	10
Socket connection.....	11

Mixer Basics

You've got yourself a mixer and now you're ready to use it.

Just plug everything in, twiddle the controls, and away you go...right?

Well, if you've done this before, you won't have any problem, but if this is the first time you've ever used a mixer you might want to read through this little tutorial and pick up a few basics that will help you get better performance and make better mixes.

Balanced, Unbalanced What's the Difference?

In a word: "noise." The whole point of balanced lines is noise rejection, and it's something they're very good at. Any length of wire will act as an antenna to pick up the random electromagnetic radiation we're constantly surrounded by: radio and TV signals as well as spurious electromagnetic noise generated by power lines, motors, electric appliances, computer monitors, and a variety of other sources. The longer the wire, the more noise it is likely to pick up. That's why balanced lines are the best choice for long cable runs. If your "studio" is basically confined to your desktop and all connections are no more than a meter or two in length, then unbalanced lines are fine unless you're surrounded by extremely high levels of electromagnetic noise. Another place balanced lines are almost always used is in microphone cables. The reason for this is that the output signal from most microphones is very small, so even a tiny amount of noise will be relatively large, and will be amplified to an alarming degree in the mixer's high-gain head amplifier.

Balanced noise cancellation

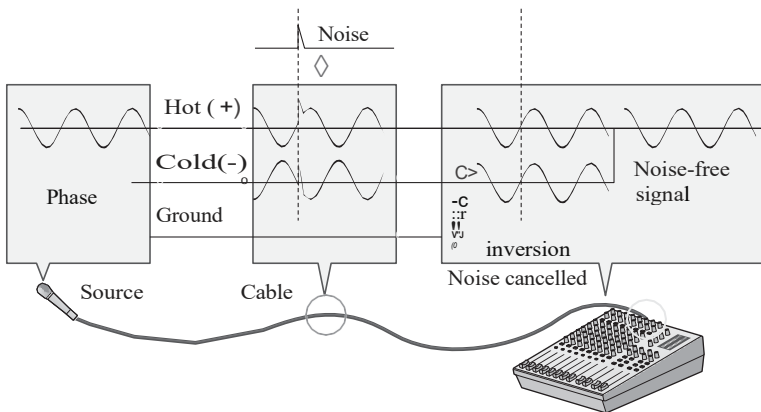

To summarize

Microphones:	Use balanced lines.
Short line-level runs:	Unbalanced lines are fine if you're in a relatively noise-free environment.
Long line-level runs:	The ambient electromagnetic noise level will be the ultimate deciding factor, but balanced is best.

Signal Levels and the Decibel

Let's take a look at one of the most commonly used units in audio: the decibel (dB). If the smallest sound that can be heard by the human ear is given an arbitrary value of 1, then the loudest sound that can be heard is approximately 1,000,000 (one million) times louder. That's too many digits to deal with for practical calculations, and so the more appropriate "decibel" (dB) unit was created for sound-related measurements. In this system the difference between the softest and loudest sounds that can be heard is 120 dB. This is a non-linear scale, and a difference of 3 dB actually results in a doubling or halving of the loudness.

You might encounter a number of different varieties of the dB: dBu, dBV, dBm and others, but the dBu is the basic decibel unit. In the case of dBu, "0 dBu" is specified as a signal level of 0.775 volts. For example, if a microphone's output level is -40dBu (0.00775 V), then to raise that level to 0 dBu (0.775 V) in the mixer's preamp stage requires that the signal be amplified by 100 times.

A mixer may be required to handle signals at a wide range of levels, and it is necessary match input and output levels as closely as possible. In most cases the "nominal" level for a mixer's inputs and outputs is marked on the panel or listed in the owner's manual.

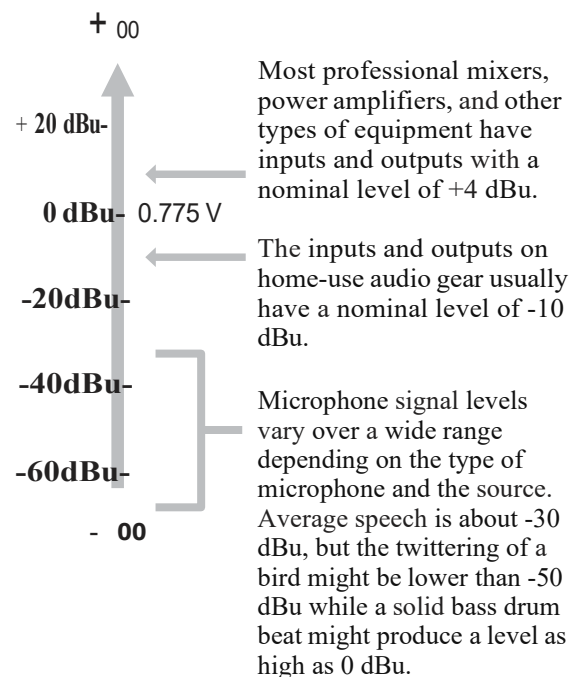

Quick Guide

J Be sure that your mixer is turned off and that all level controls* are turned all the way down.

* STEREO OUT Master fader, Channel faders, GROUP 1-2 faders, GAIN controls, etc.

Note:

Set the equalizer and the PAN controls to their positions.

2 Turn off any other external devices, then connect microphones, instruments and speakers.

Note:

* For information on connecting external devices see the Connection Example on page 11.

* Connect electric guitars and basses through an intermediary device such as a direct box, preamp, or amp simulator. Connecting these instruments directly to the professional audio mixer may result in degraded sound and noise.

3 To avoid damage to your speakers, power up the devices in the following order: Peripheral devices-professional audio mixer-power amps (or powered speakers). Reverse this order when turning power off.

NOTE:

If you are using condenser microphones that require phantom power, turn the professional audio mixer's phantom power switch on before turning on the power to the power amp or powered speakers.

4 Adjust the channel GAIN controls so that the corresponding PEAK indicators flash briefly on the highest peak levels.

Note:

To use the level meter to get an accurate reading of the incoming signal level, turn the channel PFL switch on. Adjust the GAIN controls so that the level meter indication occasionally rises above the "0" level.

Note that PHONES jacks output pre-fader signals from all channels with their PFL switches set to the ON position so that these signals can be monitored via the headphones.

5 Set the STEREO OUT Master fader to the "0" position.

6 Set the Channel faders to create the desired initial balance, then adjust the overall volume using the STEREO OUT Master fader.

NOTE:

- * To use the level meter to view the level being applied to the STEREO L/R buses, set the PFL switch off (•)-
- * If the PEAK indicator lights frequently, lower the Channel faders a little to avoid distortion.

Channel Control Section

通道控制部分

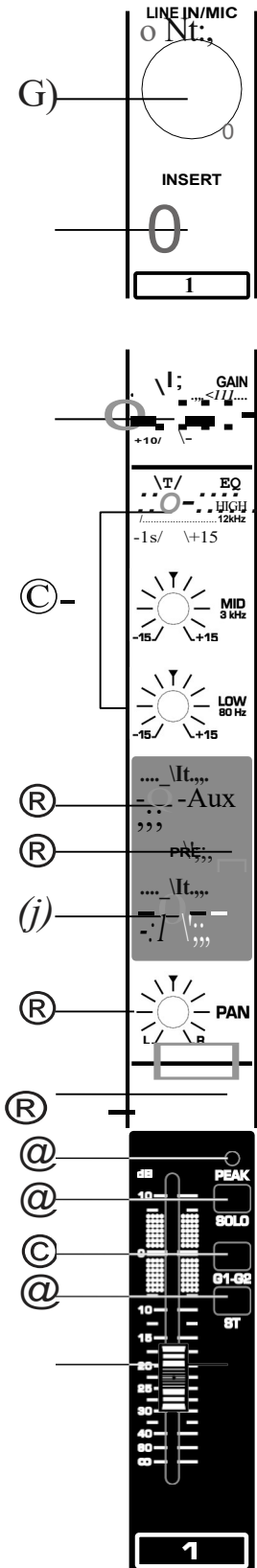

0 MIC/LINE input jack

These are balanced XLR-type microphone input jacks.

8 INSERT JACK

Each of these jacks provides an insert point between the respective input channel equalizer and attenuator. The INSERT jacks can be used independently as graphic equalizers, compressors, or noise filters and other devices to access the appropriate channel. These jacks are TRS (tip, ring, sleeve) phone jacks that carry both the send signal and return signal (tip= send/ output; ring= return/ input; sleeve= ground).

Patching external devices via an INSERT jack requires the use of special insert shown below cable (connector cable sold separately).

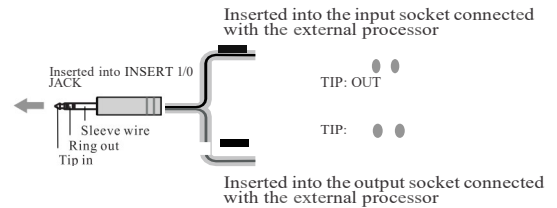

The input signal is inverted INSERT socket. This should not be a problem when connecting to an effect unit, but note that there may be a phase conflict when connecting to another type of device.

9 GAIN controls

Adjust the input signal level. In order to get the best balance signal to noise ratio and dynamic range, adjust the gain so that the PEAK indicator (fl) lights up only occasionally and briefly on the highest input transients.

Equalizer (HIGH, MID and LOW)

This three-band equalizer adjusts the channel's high, mid, and low frequency bands. Setting the knob to the "T" position in the corresponding band produces a flat response. Turning the knob to the right boosts the corresponding frequency band, while turning to the left attenuates the band. Monaural channels have MID frequency controls to adjust the midrange frequency band.

The following table shows the three bands of EQ type, frequency, and maximum cut/ boost.

Frequency band	Stpy	Frequency	Maximum weakening/enhancement
HIGH	Slope shape	12kHz	±15 dB
MID	Peak shape	2.5 kHz	
LOW	Slope shape	80Hz	

AUX control knob

Adjustment sent from the channel to the AUX bus signal level. This knob should generally be set close to the "T" position. On stereo channels, the signals L and R channels are mixed and sent to the AUX bus.

AUX PRE SWITCH

Choose whether to send the pre-fader or post-fader signal to the AUX bus. If this switch is on (L), the mixer sends the pre-fader signal (before the channel fader I signal) is sent to the AUX bus, so that AUX output is not the impact attenuator. If the switch is off (-), the mixer sends the post-fader signal to the AUX bus.

Channel Control Section

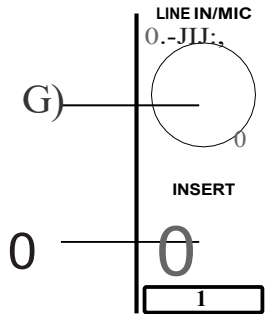

EFFECT Control knob

Sent from the channel to adjust AFFECT bus signal level. Note that the channel fader will affect the signal sent to the bus level.

PAN Control knob

The PAN control adjusts the channel signal on the STEREO Land R buses stereo position.

MUTE Indicator

Press the MUTE switch(.-) MUTE indicator lights up red.

PEAK Indicator

After detecting the peak level of the signal EQ. When the level reaches below clipping 3dB, PEAK indicator lights yellow.

PFL Switch

This switch lets you monitor the channel's pre-fader signal. Press the switch(.-) so that it lights up. When the switch is turned on, the channel pre-fader signal is output to the PHONES jack for monitoring .

1-2 Switch

This switch the channel's signal to the GROUP 1 and 2 buses. 15.ST switch

ST Switch

This switch assigns the channel signal to the STEREO Land R buses.

Channel faders

Adjust the level of the channel signal. Use these faders to adjust the balance between the various channels.

la Unused channel faders maximum to reduce noise.

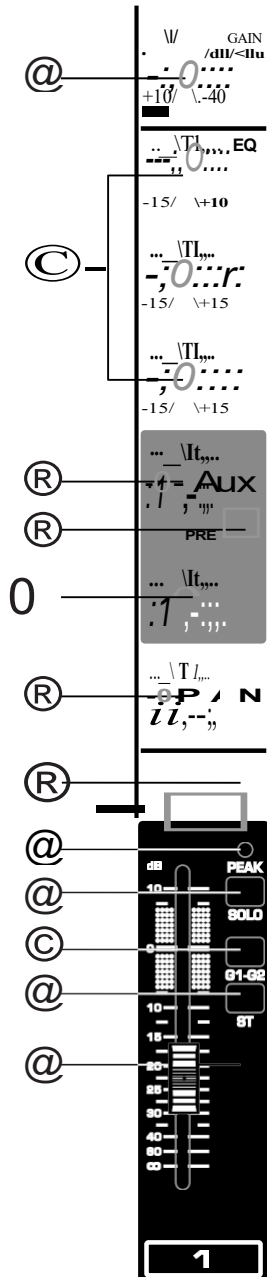

Main section

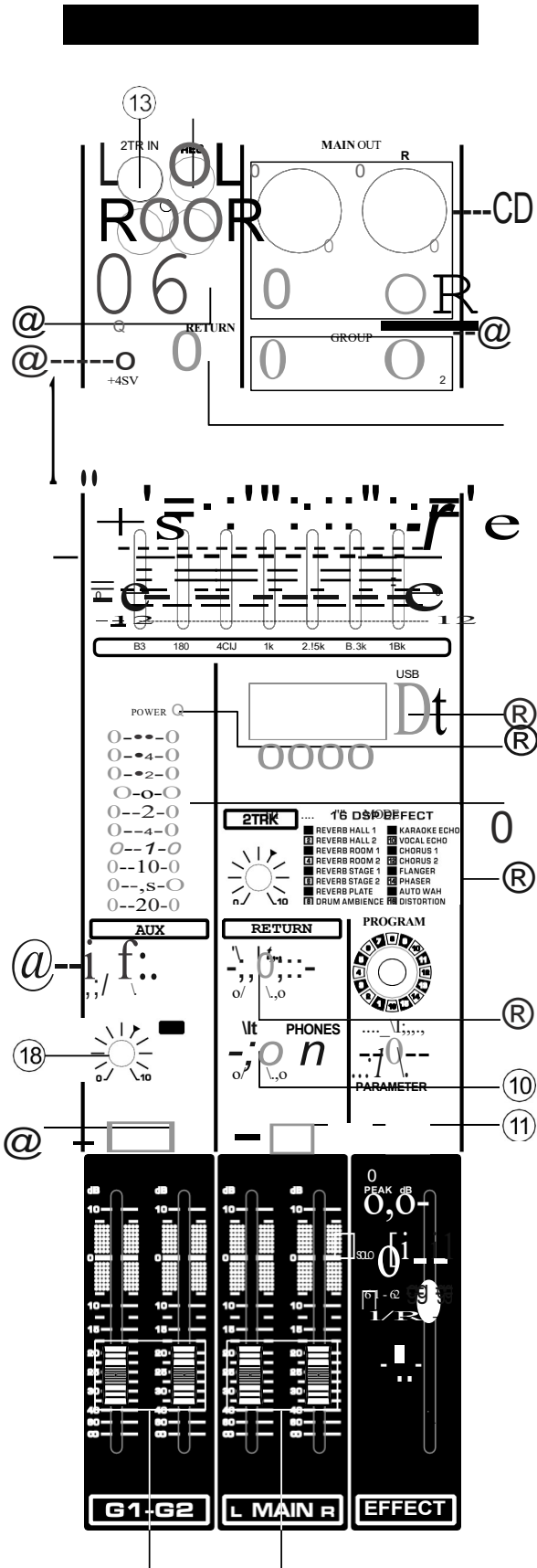

MAIN OUT L R Jack

These jacks deliver the mixer's stereo output. Use these jacks to connect to the power amplifier driving your main speakers. Using MAIN OUT master fader level control while recording professional Stereo output audio mixer, you can also connect these jacks to a recording device

Jack

These impedance-balanced phone jacks output the GROUP signal. Can use these jacks to connect multi track recorder, or other such input devices jack.

RETURN L (MONO) R Jack

These are unbalanced phone-jack line input jack. Signal received by these jacks is sent to the STEREO L / R bus and AUX bus. Stereo signal is returned a mono mix signal is sent to the AUX 1 and AUX2 buses. These jacks are typically used to receive a return from an external effect device (reverb, delay, etc.).

- These jacks can also be used as an auxiliary stereo input.
- If you connect to the L (MONO) jack, the mixer will recognize the signal as mono signal to both the L and R jacks to send the same signal.

Graphic Equalizer

The seven-band graphic equalizer adjustment sent to the MAIN OUT jacks of an audio signal. EQ cut or boost each frequency band (125, 250, 500, 1k, 2k, 4k and 8k Hz) within ± 12 dB range.

Music player

High quality music player, there will MP3, WMA music files into the player's U disk socket, via USB knob to control the playback of high quality music. This player comes with a Bluetooth function and the recording function using the "MODE" button to switch.

POWER indicator

After the mixer's power, this indicator lights.

LED level indicator

This table shows the LED MAIN and PHONE signal level. "0" segment corresponds to the nominal output level. When the output level reaches the clipping level red.

2 TRK control knob

It is adjustable from 2 TRK IN jack to transmit the signal level STEREO L / R bus.

RETURN control knob

Adjustment will send RETURN jack L (MONO) and L / R signal received by the R AUX bus level.

PHONES control

Regulation and control PHONES jack output level.

T / G1-G2 switch

This switch can be output signal ST or GROUP switched to PHONES for monitoring, LED level meter display by.

Main control section

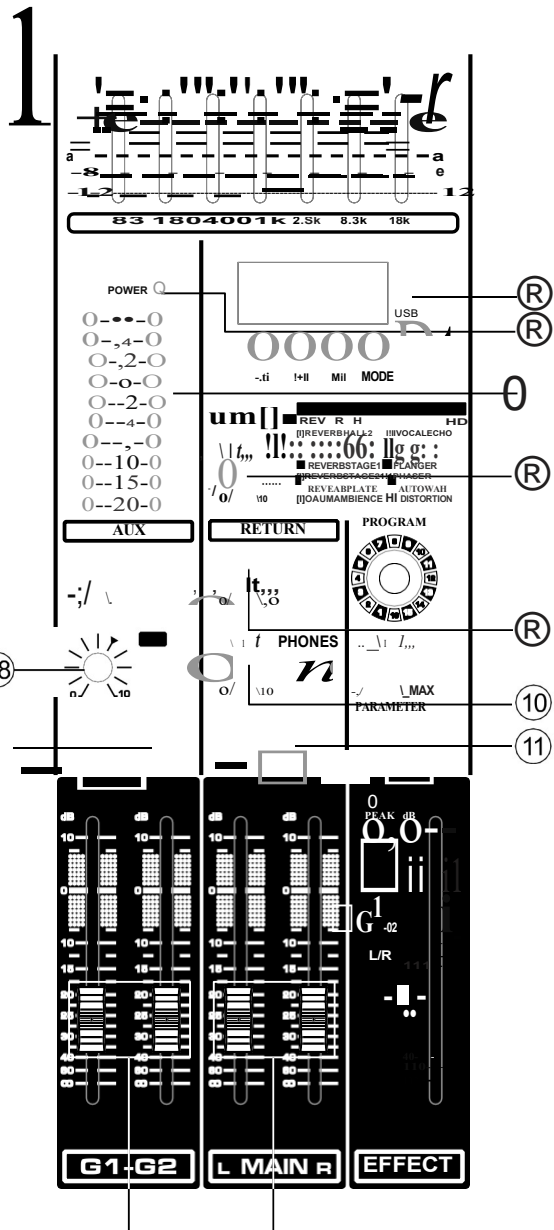
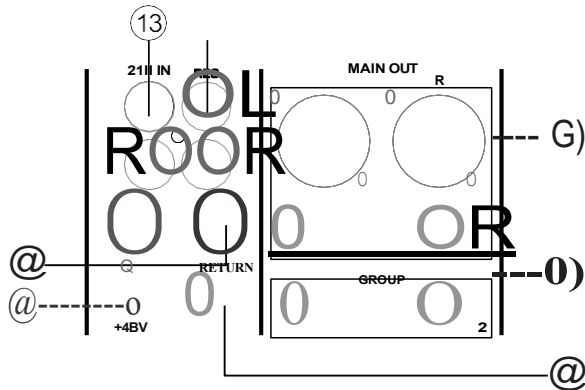

GROUP attenuator

To adjust the send GROUP OUT jack signal level.

MAIN attenuator

Adjust the send to MAIN OUT jack signal level.

EC OUT

These RCA pin jacks can be connected to the MD recorder then loaded on the recorder in order to record the STEREO OUT jacks output signals of the same signal.

1B Mixer's STEREO OUT Master fader has no effect on the output signal of these jacks. Make sure the recording device appropriate level adjustment.

2 TRK IN

These RCA pin jacks can be used to input a stereo sound source. Would like a CD player directly to the mixer, you can use these jacks.

1B Available Master Control section 2TRK IN Control Adjusts the signal level.

Bluetooth devices

Switch to bluetooth MODE by {MODE} of (5), you can control bluetooth music player to play high quality music

END Jack

- **AUX** This is an impedance balanced phone-jack type output. This jack outputs the signal from AUX bus, you can use this jack to connect the effect unit, video, or other monitoring systems.
- **EFFECT** This is an impedance balanced phone-jack type output, the output from the EFFECT bus signals, use this jack to connect an external effect unit.

PHANTOM +48 Power Switch

This switch toggles phantom power. When this switch is open, Mixer will have XLR mic input jacks provide +48V channel Phantom power. Using one or more phantom-powered electric power When Yung microphone, turn on the switch.

!!!SI When this switch is on, the mixer all XLR-type MIC INPUT jack pins 2 and 3 provide DC+ 48V power supply.

cautions

- If you do not need phantom power, be sure to turn off this switch(R).
- When turning the switch on(---), be sure that only condenser cylinder connected to the XLR input jacks. In addition, if the capacitance words equipment connected to the outside of the cylinder phantom power, may damage bad equipment. However, please note that when connecting to balanced dynamic The microphone, the switch may be left on.
- To avoid damage to speakers, turn on or turn off this switch before, be sure to turn off amplifiers (or powered speakers). Recommended before operating the switch, all the output control knob (MAIN-L, MAIN- R master fader device) to their minimum settings to avoid excessive noise Cited from hearing loss or device damage.

AUX control knob

Adjust the send to AUX SEND socket signal level.

EFFECT control knob

Adjust the send to EFF SEND socket signal level.

LINES/ USB switch

Audio source input signal this switch [LINE] stereo input signal and the USB music player switching signals to CH 7/8 USB [CH 1/1/2 USB] [CH 1/5/1/6 USB] on.

Digital effects section and a rear panel

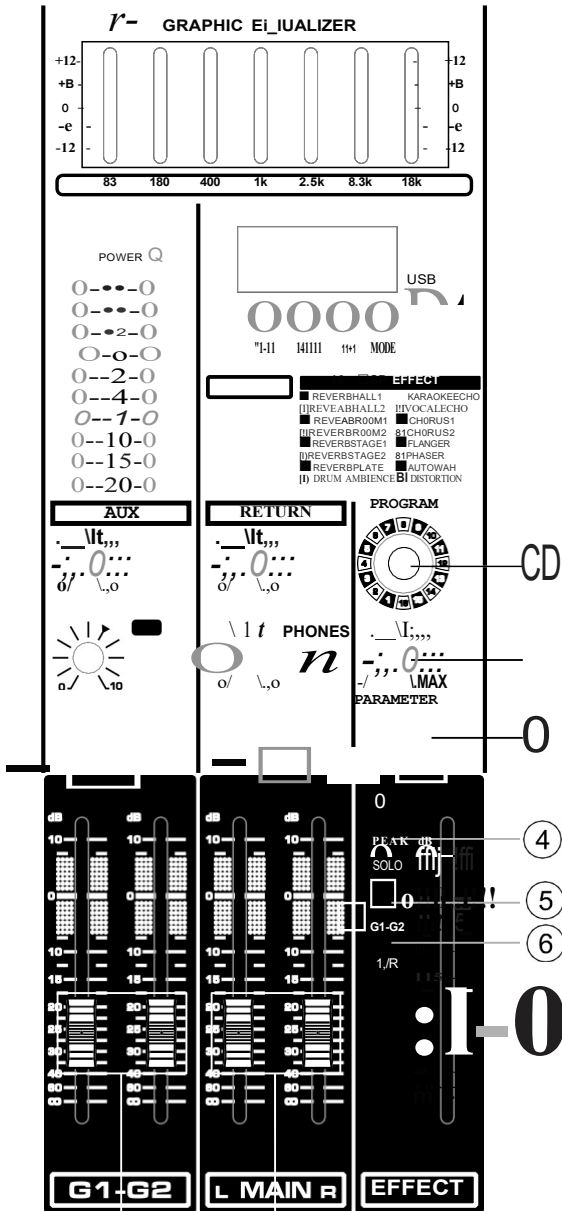

PROGRAM Dial

Choose one of the 16 internal effects. For more information about the internal effects, see page 11.

PARAMETER Jack

Adjust the selected effect parameter (depth, speed, etc.). Parameter values for each effect type last used will be saved. **When** you change to a different effect type, the newly selected effect, the mixer automatically restores the value that was previously used (whether PARAMETER controls the current position). When the power is turned off, these parameters will be reset.

EFF MUTE Switch

Turn on or off the internal effect. Only turn on this switch, to apply internal effects. Yellow light off (press) switch.

PFL Switch

Turn this switch sends a digital effect signal to the PFL bus. Press the switch (---) so that it lights up. When the switch is turned on, the channel pre-fader signal is output to the PHONES jack for monitoring.

1-2 Switch

This switch signal is output to digital effects GROUP 1 and 2 buses.

ST Switch

This switch digital effect signal to MAIN and R buses.

EFFECT Attenuator

Digital effect adjustment signal sending large STEREO bus level.

POWER Switch

Power switch

AC INPUT Jack

AC 17V input, the supplied AC power adapter to this jack.

Caution Use only the power adapter supplied with the unit, use a different power adapter may result in fire or electric shock.

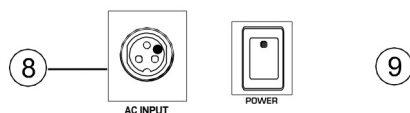

Rear panel

Digital effects Program List

No.	Program	Parameter	Explanation
	REVERB HALL 1	REVERB TIME	Reverb simulation large space such as a concert hall
2	REVERB HALL 2	REVERB TIME	
3	REVERB ROOM 1	REVERB TIME	
4	REVERB ROOM 2	REVERB TIME	Simulation of a small space (room) sound reverberation
5	REVERB STAGE 1	REVERB TIME	
6	REVERB STAGE 2	REVERB TIME	Reverb simulation stage
7	REVERB PLATE	REVERB TIME	
8	DRUM AMBIENCE	REVERB TIME	Analog metal plate reverb unit, in order to produce a more powerful sound
9	KARAOKE ECHO	DELAY TIME	Bass drum using the same short reverberation
10	VOCAL ECHO	DELAY TIME	Echo for karaoke
11	CHORUS 1	LFO FREQUENCY	Suitable for vocal echo
12	CHORUS 2	LFO FREQUENCY	
13	FLANGER	LFO FREQUENCY	It creates a thick sound by modulating the delay time. The PARAMETER control adjusts the frequency modulation LFO delay time
14	PHASER	LFO FREQUENCY	A sweeping pitched effect. The PARAMETER control adjusts the frequency modulation LFO delay time
15	AUTO WAH	LFO FREQUENCY	Phase modulation produces a cyclical phasing effect The PARAMETER control adjusts the frequency modulation LFO delay time
16	DISTORTION	DRIVE	With cyclical filter modulation wow sound effects. The PARAMETER control adjusts the frequency modulation LFO delay time
			Add sharp edges distortion in the sound

LFO stands for Low Frequency Oscillator. LFO is normally used to modulate another signal, determining the modulation speed of the waveform.

Jack List

Input and Output Jacks	Polarities	Configuration
MIC INPUT, STEREO OUT	Pin 1: Ground Pin 2: Hot(+) Pin 3: Cold (-) INPUT OUTPUT	<p>INPUT OUTPUT</p>  <p>XLR Jack</p>
LINE INPUT (8 nonaural channels) GR UP OUT, STEREO OUT, MONITOR OUT, AUX SEND, EFFECT SEND	Tip: Hot (+) Ring: Cold (-) Sleeve: Ground	<p>Ring</p> <p> </p> <p>Sleeve Tip TRS Phone Jack</p>
INSERT	Tip: Output Ring: Input Sleeve: Ground	
PHONES	Tip: L Ring: R Sleeve: Ground	
RETURN LINE INPUT (stereo channels)	Tip: Hot Sleeve: Ground	Sleeve Tip Phone Jack

* These jacks will also accept connection to phone plugs. If you use monaural plugs, the connection will be unbalanced.

Specifications

Input Specifications

Input Connectors	Gain	Input Impedance	Appropriate Impedance	Sensitivity*	Nominal Level	Max. before Clipping	Connector Specifications
CH INPUT MIC	-60 dB	3k!1	50-600!1 Mies	-80 dBu (0078 mV)	-60 dBu (0.775 mV)	-40 dBu (7.75 mV)	XLR 3-31 type (balanced 1=GND, 2=HOT, 3=COLD)
	-16 dB			-36 dBu (12.3 mV)	-16dBu (123mV)	+4 dBu (1.23 V)	
CH INPUT LINE	-34 dB	10k!1	600!1 Lines	-54 dBu (1.55 mV)	-34 dBu (15.5 mV)	-14 dBu (155 mV)	TRS phone jack (balanced Tip= Hot, Ring= Cold, Sleeve= GND)
	+10 dB			-10dBu (245mV)	+10dBu (245V)	+30 dBu (24.5 V)	
RETURN (L, R)		10kQ	600!1 Lines	-12dBu (195mV)	+4dBu (1.23V)	+24 dBu (12.3 V)	Phone jack (unbalanced)
2TRIN(L, R)		10kQ	600!1 Lines	-26 dBV (50.1 mV)	-10dBV (0.316V)	+10dBV (316V)	RCApinjack

Where 0 dB= 0.775 Vrms, 0 dBV = 1 Vrms

* Sensitivity: The lowest level that will produce an output of +4dB (1.23 V), or the nominal output level when the unit is set to the maximum level. (All faders and level controls are at their maximum position.)

Output Specifications

Output Connectors	Output Impedance	Appropriate Impedance	Nominal Level	Max. before clipping	Connector Specifications
MAIN OUT (L, R)	75!1	600!1 Lines	+4dBu (1.23 V)	+24 dBu (12.3 V)	XLR-3-32 type (balanced 1=GND, 2=HOT, 3=COLD) phone jack (balanced Tip= HOT, Ring= COLD, Sleeve= GND)
EFFECT/AUX (AUX1, 2*) SEND	150!1	10kQ Lines	+4dBu (1.23 V)	+20 dBu (7.75 V)	phone jack (impedance balanced Tip = Hot, Ring= Cold, Sleeve= GND)
REC OUT (L, R)	600!1	10kQ Lines	-10dBV (0316V)	+10 dBV (3.16 V)	RCA pin jack
PHONES OUT	100!1	40!1 Phones	3mW	75 mW	STEREO phone jack

Where 0 dBu = 0.775 Vrms and 0 dBV = 1 Vrms.

Jack Wiring

